

# Owner's Manual

- *Installation*
- *Use*
- *Maintenance*



General Pump  
is a member of  
the Interpump Group



## INDEX

<b>1.</b>	<b>INTRODUCTION</b> .....	Page 4
<b>2.</b>	<b>SYMBOL DESCRIPTIONS</b> .....	Page 4
<b>3.</b>	<b>SAFETY</b> .....	Page 4
	3.1 General safety warnings .....	Page 4
	3.2 High pressure unit safety requirements .....	Page 4
	3.3 Safety during operation .....	Page 5
	3.4 General procedures for using nozzles .....	Page 5
	3.5 Safety during unit maintenance .....	Page 5
<b>4.</b>	<b>PUMP IDENTIFICATION</b> .....	Page 6
<b>5.</b>	<b>TECHNICAL CHARACTERISTICS</b> .....	Page 6
<b>6.</b>	<b>DIMENSIONS AND WEIGHTS</b> .....	Page 7
<b>7.</b>	<b>INFORMATION REGARDING PUMP USE</b> .....	Page 8
	7.1 Water temperature .....	Page 8
	7.2 Maximum flow and pressure values .....	Page 8
	7.3 Lowest operating RPM .....	Page 8
	7.4 Recommended lubricant types and Manufacturers .....	Page 8
<b>8.</b>	<b>PORTS AND CONNECTIONS</b> .....	Page 10
<b>9.</b>	<b>PUMP INSTALLATION</b> .....	Page 11
	9.1 Installation .....	Page 11
	9.2 Direction of rotation .....	Page 11
	9.3 Hydraulic connections .....	Page 12
	9.4 Pump feeding .....	Page 12
	9.5 Inlet line .....	Page 12
	9.6 Filtration .....	Page 13
	9.7 Outlet line .....	Page 14
	9.9 Internal diameter of hose .....	Page 15
<b>10.</b>	<b>START UP AND OPERATION</b> .....	Page 16
	10.1 Preliminary inspections .....	Page 16
	10.2 Starting up .....	Page 17
<b>11.</b>	<b>PREVENTATIVE MAINTENANCE</b> .....	Page 17
<b>12.</b>	<b>STOPPING THE PUMP FOR LONG PERIODS</b> .....	Page 18
	12.1 Filling the pump with anti-corrosion emulsion or anti-freeze .....	Page 18
	12.2 Hoses .....	Page 18

**INDEX (continued)**

**13. PRECAUTIONS AGAINST FREEZING** ..... Page 18

**14. WARRANTY TERMS** ..... Page 18

**15. TROUBLESHOOTING** ..... Page 19

**16. EXPLODED VIEWS AND PARTS** ..... Page 20

**17. MAINTENANCE LOG** ..... Page 24

## 1. INTRODUCTION

This manual describes the use and maintenance instructions of the LK pump, and should be carefully read and understood before using the pump. The proper functioning and lifetime of the pump depends on correct use and proper maintenance. General Pump declines all responsibility for damage caused due to negligence and/or failure to observe the instructions described in this manual. Upon delivery, check that the pump is undamaged and complete. Report any problems before installing and starting the pump.

## 2. SYMBOL DESCRIPTIONS



**Warning**  
Potential Danger

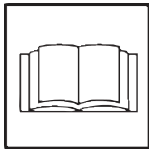

Carefully read and understand the manual before operating the pump



**Danger**  
Danger of Electrocution



**Danger**  
Wear protective mask



**Danger**  
Wear goggles



**Danger**  
Wear protective gloves



**Danger**  
Wear protective boots



**Symbol for protection against explosion**

This defines special safety requirements for the use of the pumps in areas identified in accordance with the ATEX Directive.

**When pumps are ordered in the ATEX configuration** because they are going to be used in potentially explosive atmosphere, you must **comply with the notes given under the headings marked with this symbol and the instructions in the supplementary instructions manual "ATEX EXPLOSION PROTECTION"**.

## 3. SAFETY

### 3.1 General Safety Warnings

Improper use of pumps and high pressure systems, and/or failure to observe the installation and maintenance instructions, can cause serious injury to persons and/or damage to property. Anyone preparing to assemble or use high pressure systems must have the necessary to do so, must be aware of the characteristics of the components to be assembled/used, and must adopt all possible precautions necessary to ensure maximum levels of safety in any operating condition. No reasonably applicable precaution must be omitted in the interests of safety, either by the installer or the operator.

### 3.2 High Pressure Unit Safety Requirements

1. The pressure line must always have a safety valve.
2. The components of the high pressure system, particularly for systems that operate predominantly outdoors, must be adequately protected from rain, cold and heat.
3. The electrical parts of the system, as well as being adequately protected from water sprays, must meet the standards specified in the regulations currently in force.
4. High pressure hoses must be correctly sized for the maximum working pressure of the system, and must always and only be used within the range of working pressure indicated by the Manufacturer of the hose. These precautions must be observed for all other accessories of the system which are connected in any way with high pressure.
5. The ends of high pressure hoses must be sheathed and anchored to a solid structure, to prevent dangerous whiplashes in the event of bursting or breakage of the connections.
6. Suitable protective casings must be installed at the pump transmission systems (junctions, belts and pulleys, auxiliary power take-offs).



### 3.3 Safety During Operation

The working area of a high pressure system must be clearly indicated. Access must be prohibited to non-authorized personnel and, as far as possible, it must be restricted or fenced off. The personnel authorized to access this area must be previously trained, and informed about the risks that may arise from failures or malfunctions of the high pressure unit.

Before starting the unit, the operator must check:

1. That the high pressure unit is correctly fed (see paragraph 9.4).
2. That pump intake filters are perfectly clean; we advise to use a device that indicates the filters clogging level.
3. That electrical parts are adequately protected and in perfect condition.
4. That high pressure hoses do not show apparent signs of abrasion, and that fittings are in perfect shape.

Any anomaly or reasonable doubt that may arise before or during operation must be promptly reported and verified by competent personnel. In these cases, pressure must be immediately released and the high pressure unit stopped.



### 3.4 General Procedures For Using Nozzles

1. The Operator must always place his own and other worker's safety before any other interest; his actions should always be dictated by good sense and responsibility.
2. The Operator must always wear a hard hat with a protective visor, waterproof clothing, and suitable boots capable of providing a good grip on wet pavement.

*Note: appropriate clothing will effectively protect against water spray, but it may not offer adequate protection against the direct impact of water jets or sprays at a close distance. Some circumstances may require further protection.*

3. It is good practice to work in teams of at least two Operators, able to provide mutual and immediate assistance if needed, and to rotate their duties in case of long and demanding tasks.
4. Access to the work area that is within the water jets' range must be absolutely prohibited; the area must be free of objects that may be inadvertently hit by the pressurized jet, causing damage or dangerous situations.
5. The water jet must only and always be directed towards the work area, even during testing or preliminary inspections.
6. The Operator must always pay attention to the trajectory of the debris removed by the water jet. If necessary, adequate side guards must be provided by the Operator in order to protect anything that may be accidentally exposed.
7. For no reason must the Operator be distracted during operation. The personnel that needs to access the working area must wait for the Operator to suspend his work, and then immediately make his presence known.
8. For safety reasons, it is important that each member of the team is completely aware of the intentions and actions of other team members in order to avoid dangerous misunderstandings.
9. The high pressure system must not be started and brought up to pressure unless each member of the team is in his designated position, and the Operator has already directed the nozzle towards the work area.

### 3.5 Safety During System Maintenance

1. Maintenance of the high pressure system must be done within the time intervals indicated by the Manufacturer, who is responsible for the entire unit's compliance with the regulations in force.
2. Maintenance must always be carried out by specialized and authorized personnel.
3. Assembly and disassembly of the pump and its various components must be performed exclusively by authorized personnel, using appropriate tools in order to avoid damage to components and connections.
4. To guarantee total reliability and safety, always use original spare parts.

## 4. PUMP IDENTIFICATION

Each pump has a rating plate bearing the following information:

- Pump model and version
- Serial Number
- Maximum RPM
- Power consumption Hp-kW
- Flow Rate in l/mn - GPM
- Pressure in bar/PSI

 For pumps ordered with the ATEX configuration. (Pos.2, Fig.1), plate **with specific ATEX marking for explosion protection.** (Pos. 3, Fig. 1) plate for locating the **grounding screw.**

 Pump model, version and serial number must always be specified when ordering spare parts.

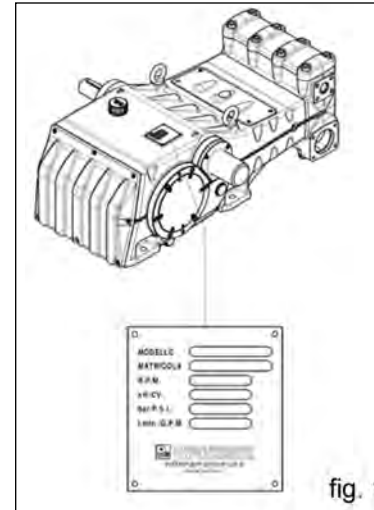

## 5. TECHNICAL FEATURES

MODEL	RPM	FLOW RATE		PRESSURE		POWER	
		GPM	l/min	PSI	Bar	Hp	kW
LK3615	1500	37.0	140	5800	400	145	107
LK3617	1750	40.2	152	5800	400	158	116
LK4015	1500	45.7	173	5075	350	157	115
LK4017	1750	49.7	188	5075	350	171	126
LK4515	1500	57.6	218	4060	280	159	117
LK4517	1750	62.9	238	4060	280	173	127
LK5015	1500	71.1	269	3335	230	161	118
LK5017	1750	77.7	294	3335	230	176	129
LK5515	1500	86.1	326	2755	190	161	118
LK5517	1750	93.8	355	2755	190	176	129
LK6015	1500	102.5	388	2320	160	161	118
LK6017	1750	111.8	423	2320	160	176	129

**6. DIMENSIONS AND WEIGHTS**

For dimensions and weight of LK36, LK40 and LK45 pumps, please refer to fig. 2.

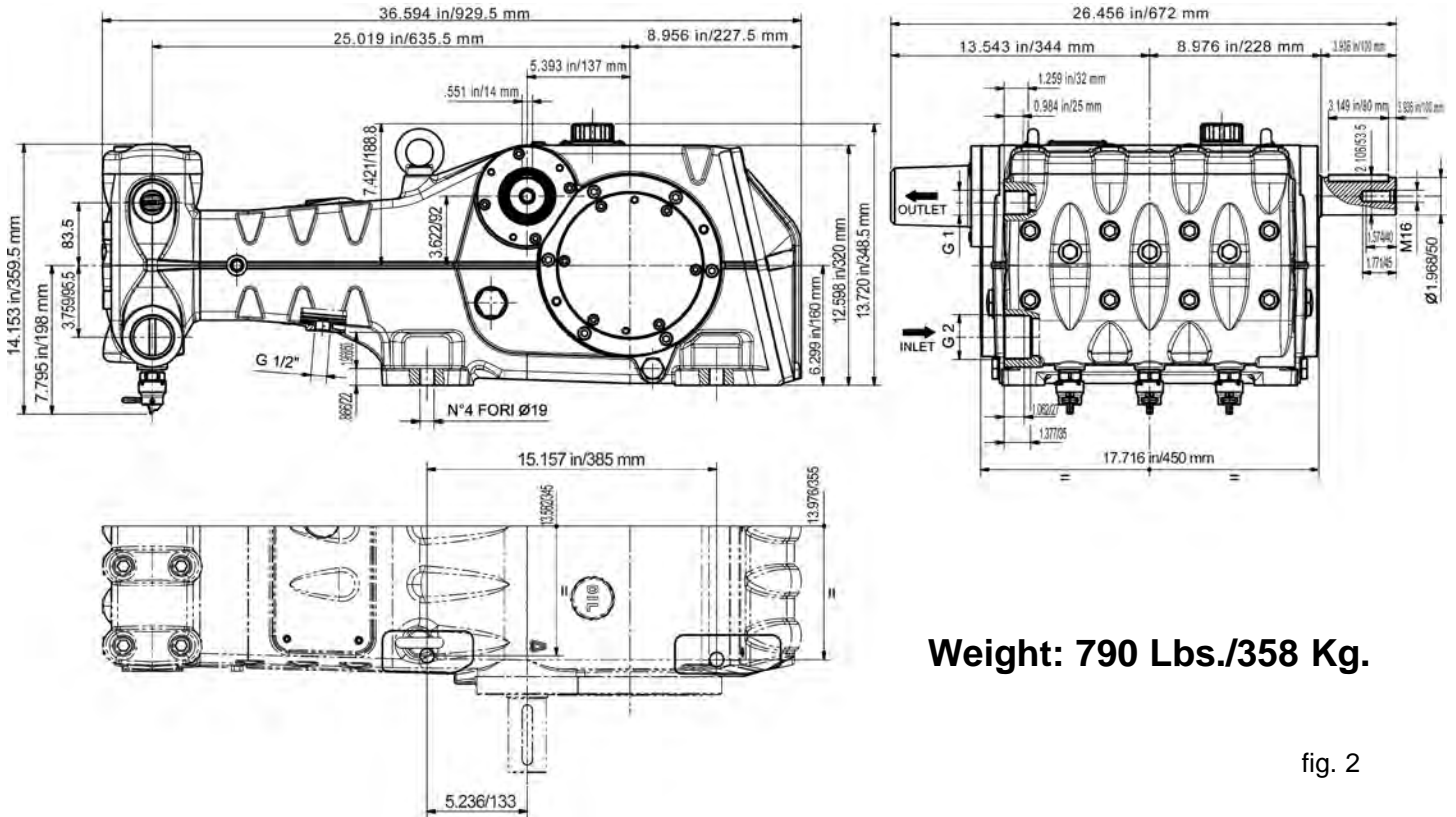

**Weight: 790 Lbs./358 Kg.**

fig. 2

For dimensions and weight of LK50, LK55 and LK60 pumps, please refer to fig. 2a.

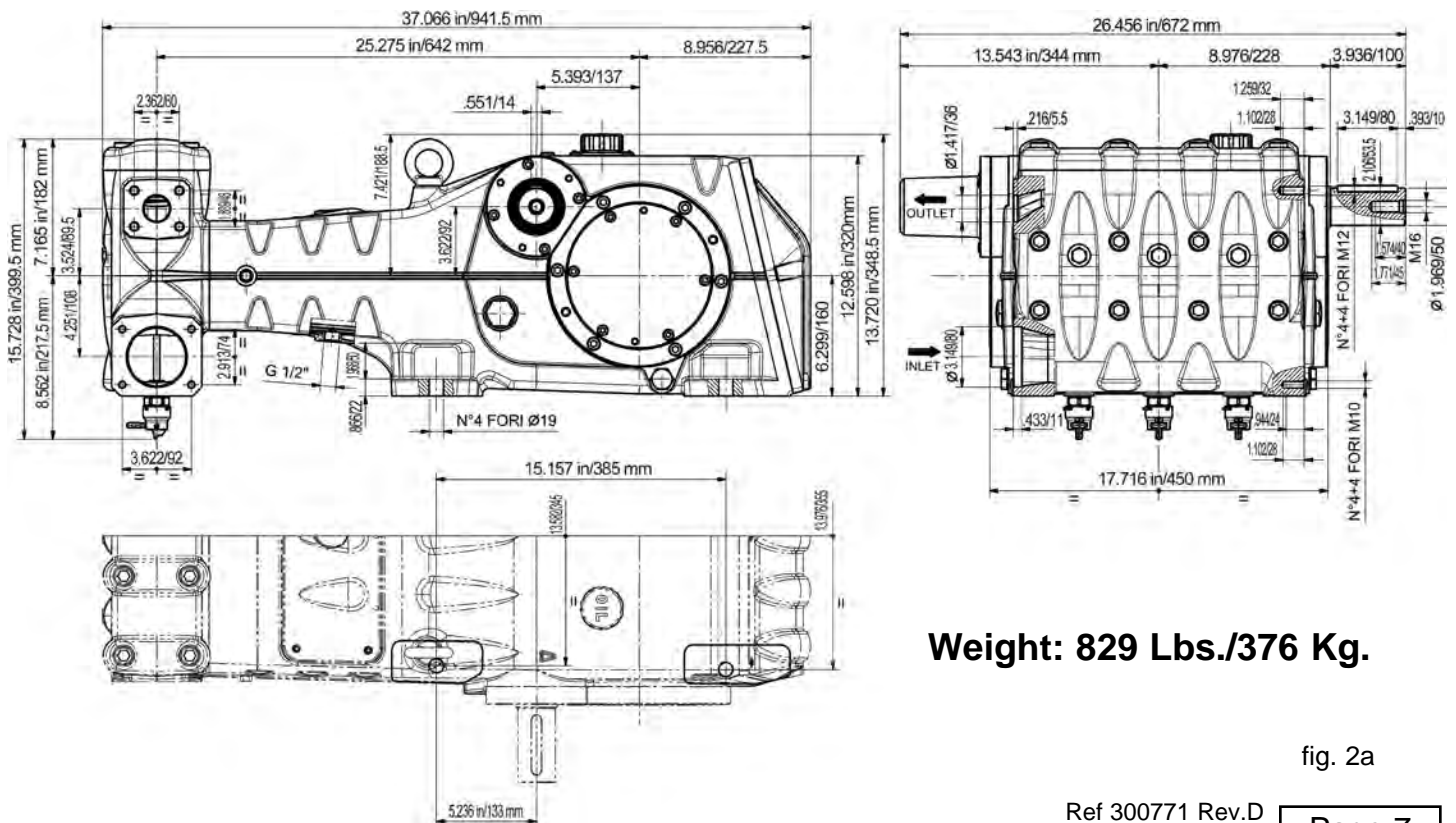

**Weight: 829 Lbs./376 Kg.**

fig. 2a

## 7. INFORMATION ABOUT PUMP USE



The LK pump, when not ordered with ATEX has been designed to operate in environments that are not potentially explosive, and with filtered water (see paragraph 9.6) and at maximum temperature of 104° F (40° C).

**Other fluids may be used only upon the approval of The Customer Service Department .**



### 7.1 Water Temperature

The max water temperature is 104° F (40° C). However, it is possible to use the pump at temperatures of up to 140° F (60° C) for short periods of time. In this case we advise consulting the Customer Service Department.

### 7.2 Max Flow Rate and Pressure Values

The performance figures given catalog refer to the maximum performance of the pump. Regardless of the power used, pressure and maximum RPM values indicated on the plate may not be exceeded unless expressly authorized by the **Customer Service Department**.

### 7.3 Lowest RPM

Any RPM value different from what is indicated in the performance table (see section 5) must be expressly authorized by the **Customer Service Department**.

### 7.4 Recommended Lubricant Oil Types & Manufacturers

The pump is delivered with lubricant oil compliant with room temperatures ranging between 32° and 86° F (0° and 30°C ). Some recommended lubricant types are indicated in the table below; these lubricants are treated with additives in order to increase corrosion protection and resistance to fatigue. As an alternative, Automotive SAE 85W-90 gearing lubricants may also be used.

BRAND	TYPE
<b>GENERAL PUMP</b>	<b>SERIES 220</b>
ARAL	Aral Degol BG220
BP	ENERGOL HLP 220
CASTROL	Hyspin VG 220, Magna 220
ELF	POLYTELIS 220
ESSO	NUTO 220
FINA	Cirkan 220
FUCHS	RENOLIN 220
MOBIL	DTE OIL BB
SHELL	TELLUS C 220
TEXACO	RANDO HD 220
TOTAL	CORTIS 220

Check the oil level with the oil level lights located on the sides (pos. 1, fig. 3). If necessary, top up via the oil plug (pos. 3, fig. 3). To correctly check the oil level, the pump must be at ambient (room) temperature. To change the oil the pump must be at operating temperature, and is done by removing the plug, (pos. 2, fig. 3). Checking and changing the oil must be done as shown in section 11. The quantity necessary is 473.3 oz. (14 liters).



Set up the plant so that the oil temperature does not exceed **212° F (100° C)** during pump operation.

Use a temperature probe to be inserted into the oil drain plug, (pos. 2, fig 3). See the "ATEX EXPLOSION PROTECTION" manual.

**ATTENTION:** Use only oil with a flash point higher than 392° F (200° C).

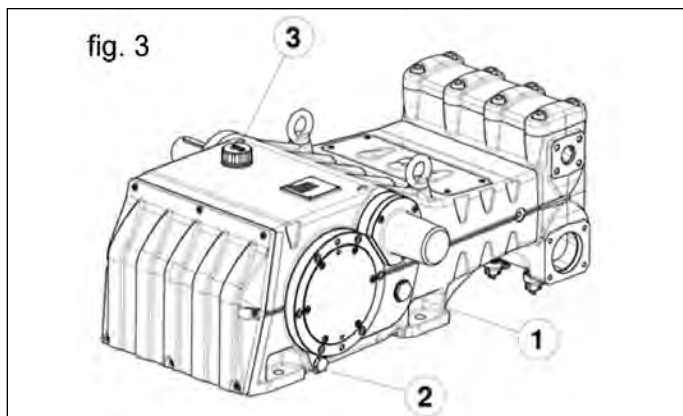





In any case, oil must be changed at least once a year since it may deteriorate by oxidation.

For room temperatures that differ from that mentioned earlier, follow the indications contained in the diagram below, keeping in mind that the oil must have a minimum viscosity of 180 cSt.

### VISCOSITY/ROOM TEMPERATURE DIAGRAM

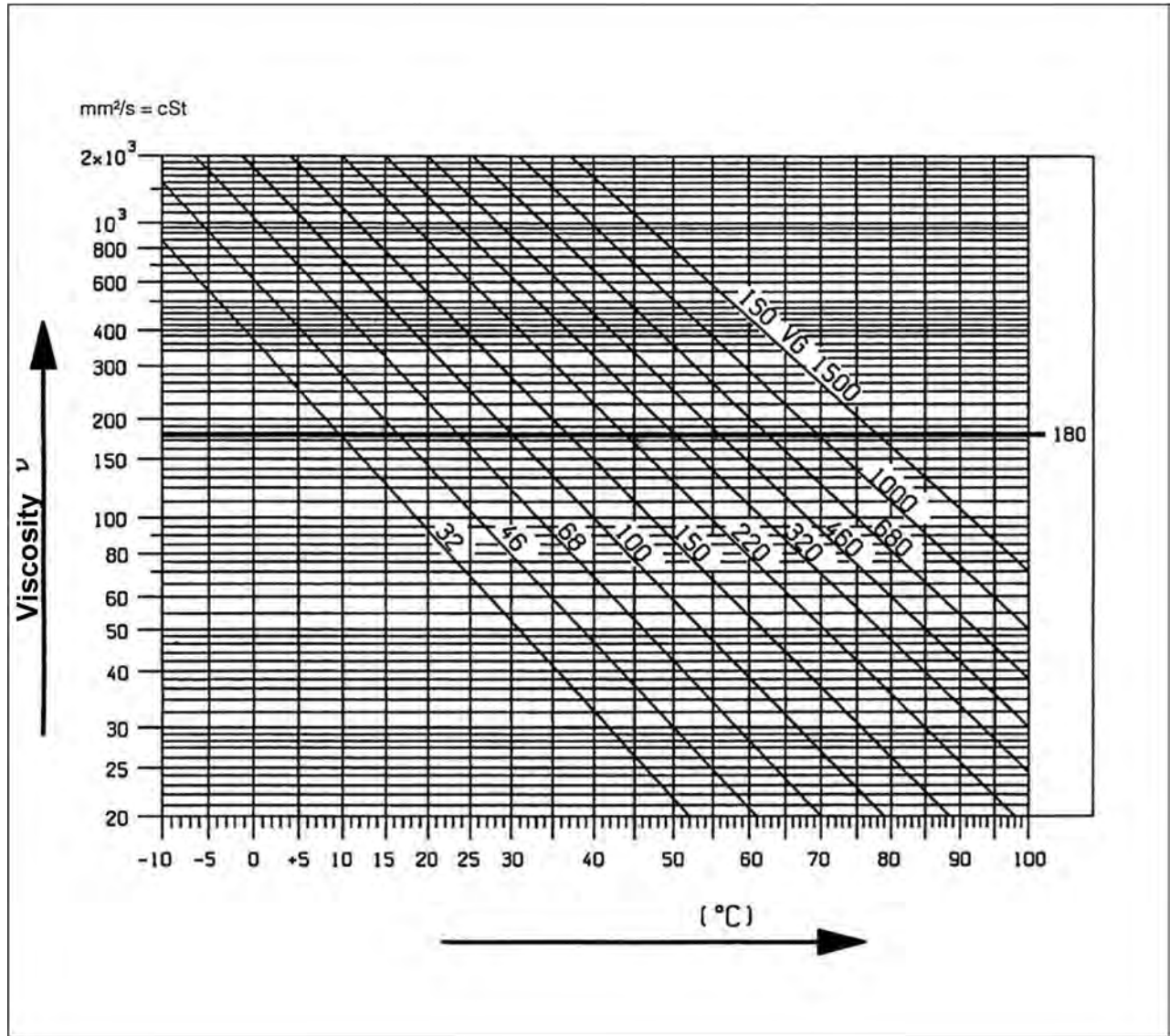

The spent oil must be placed in a suitable container and disposed of properly at an authorized center. Do not under any circumstances discard it in the environment.

**8. PORTS AND CONNECTIONS**

The LK Series pumps (see fig. 4 and 5) are provided with:

- 2 inlet ports "IN", 2" BSP-F (LK36, LK40, LK45)
- 2 inlet ports "IN", 80 mm Flange (LK50, LK55, LK60).

For the pump to work properly, it does not matter which of the 2 ports the line is connected to. Unused port must be hermetically sealed.

- 2 outlet ports "OUT", 1" BSP-F-F (LK36, LK40, LK45)
- 2 outlet ports "OUT", 36 mm Flange (LK50, LK55, LK60)

1 drain port "DRAIN" with G1/2" hole in the lower cover to monitor any water leakage due to wear of the pressure packings. In case of leaks, please consult the repair manual.

**This hole must always be kept open and clear.**

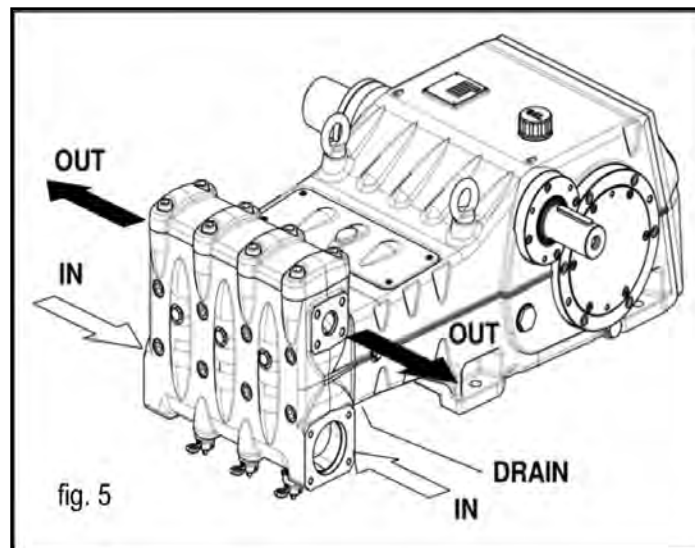
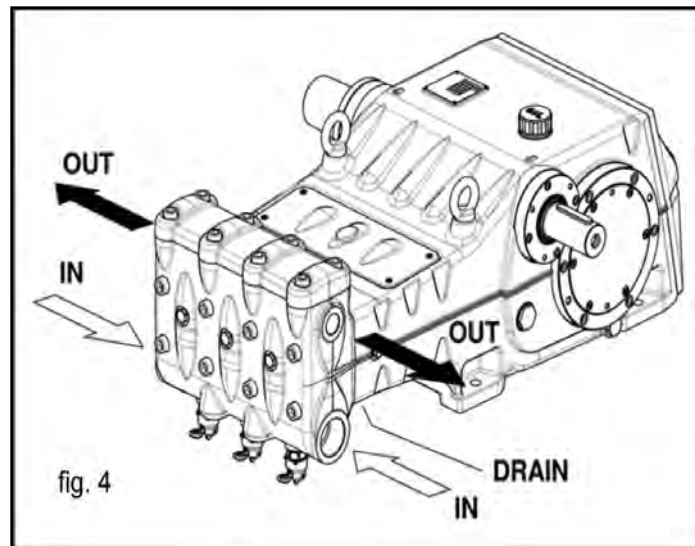

**9. PUMP INSTALLATION**

**9.1 Installation**

The pump must be installed in a horizontal position using the drilled Ø .75 in (19 mm) feet. The base must be perfectly flat and sufficiently rigid in order to avoid bending and misalignments on the pump/transmission coupling axis due to the torque applied during operation.

The pump is equipped with two lifting eyebolts to facilitate installation, as shown in the following figure.



**The eyebolts are designed for lifting the pump only, and they must never, under any circumstances, be used to lift additional loads.**



**Replace the oil filler closing plug located on the casing with the oil filler cap.** The oil filter cap must always be reachable, even when the unit is assembled.



**Grounding:** It is necessary to fix a grounding cable to the pump by means of the M8 stainless steel screw and the stainless steel toothed washer properly marked by the YELLOW label. See the "ATEX EXPLOSION PROTECTION".



**The pump's shaft (PTO) must not be rigidly connected to the motor unit.** The following transmission types are suggested:

- Flexible coupling
- Cardan coupling (follow the maximum working angles recommended by the Manufacturer)



In all cases, the transmission must be properly assembled to avoid incorrect or harsh operation of the connection parts and prevent excessive wear, an increase in temperature and/or hazardous breakages that may create potential sources of ignition and explosion. See the "ATEX EXPLOSION PROTECTION " manual.

**9.2 Direction of rotation**

The direction of rotation is indicated by an arrow positioned near the power take-off (PTO) shaft. If you stand in front of the pump head, the direction of rotation should be as in fig. 6.

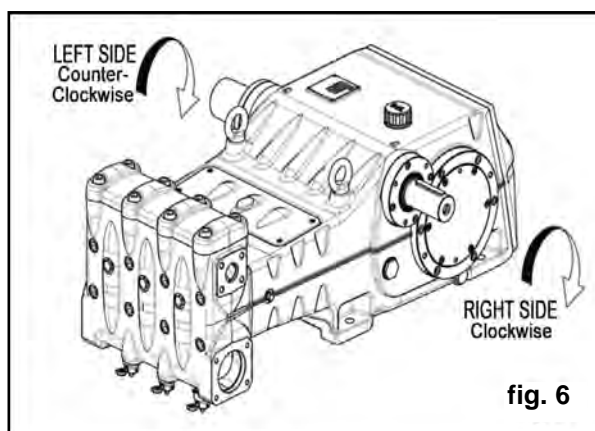

The power take-off can be taken from either side of the pump. Generally the pump is supplied with the PTO shank for the right-hand side (see fig. 6). To get the PTO from the left-hand side, the shaft end cover must be taken off and remounted on the right hand side of the pump (see 2.1.1 in the repair manual). Vice-versa, the lug must be removed from the right-hand side and inserted in the shank of the left-hand side.

### 9.3 Hydraulic Connections

In order to isolate the system from the vibrations produced by the pump, we recommend building the first section of the hose near the pump (both for intake and delivery) with flexible hose. The solidity of the intake section must allow to avoid deformation caused by the depressurization produced by the pump.

### 9.4 Pump Supply

LK pumps must always be installed under positive suction head, i.e. it must receive water falling from above or from a supply under pressure, and it must never “suck” water from a lower level. The pumps can tolerate minimum water heads of 1 meter. However, to obtain the best volumetric output and, especially, to prevent cavitation, the available net positive suction head (NPSH<sub>r</sub> avail), measured at the inlet flange at the head, must be greater than or equal to the values below:

	LK36	LK40	LK45	LK50	LK55	LK60
<b>NPSH<sub>r</sub> (m)</b>	4	4.5	5.5	6.5	7.5	8

For pumps of greater capacity, i.e. LK50, LK55 and LK60, supply under pressure from a booster pump is strongly recommended to avoid cavitation, due to the geometry of the hydraulic part and the high flow rates. The booster pump must have a flow rate of at least double that of the rated flow rate of the plunger pump, and a pressure of between 30 and 44 PSI (2 and 3 bar). These supply conditions must be respected for any and all working systems.



**Booster start-up must always be started before the plunger pump. In order to protect the pump, we advise installing a pressure switch on the supply line downstream of the filters.**

### 9.5 Inlet Line

For the pump to function well, the inlet line must have the following characteristics:



1. Minimum internal diameter as indicated in the diagram in paragraph 9.8, and in any case equal or greater than that of the pump head. Along the duct, avoid localized diameter reductions that may cause pressure drops with subsequent cavitation. Absolutely avoid 90° elbows, connections with other hoses, bottlenecks, counter-slopes, upside down “U” shaped curves, “T” connections.
2. The selected lay-out must allow to avoid cavitation.
3. It should be perfectly airtight, and built in a way that guarantees perfect sealing over time.
4. Avoid pump emptying when stopping (even partial emptying).
5. Do not use hydraulic-type fittings, 3 or 4 way fittings, adapters, etc., since they may hinder the pump’s performance.
6. Do not install Venturi tubes or injectors for detergent intake.
7. Avoid the use of standing valves, check valves, or any other type of one-way valves.
8. Do not connect the by-pass line from the valve directly to the pump suction line.
9. Provide appropriate baffle plates inside the tank in order to avoid water flows coming from both the by-pass and feeding lines may create turbulence near the tank’s outlet port.
10. Make sure that the suction line is perfectly clean inside before connecting it to the pump.
11. The pressure gauge for checking booster pressure must be installed near the plunger pump’s outlet port, and always downstream of the filters.

**9.6 Filtration**

Two filters must be installed on the pump inlet line, positioned as shown in fig. 7 and fig. 7a

With manually-actuated control valve:

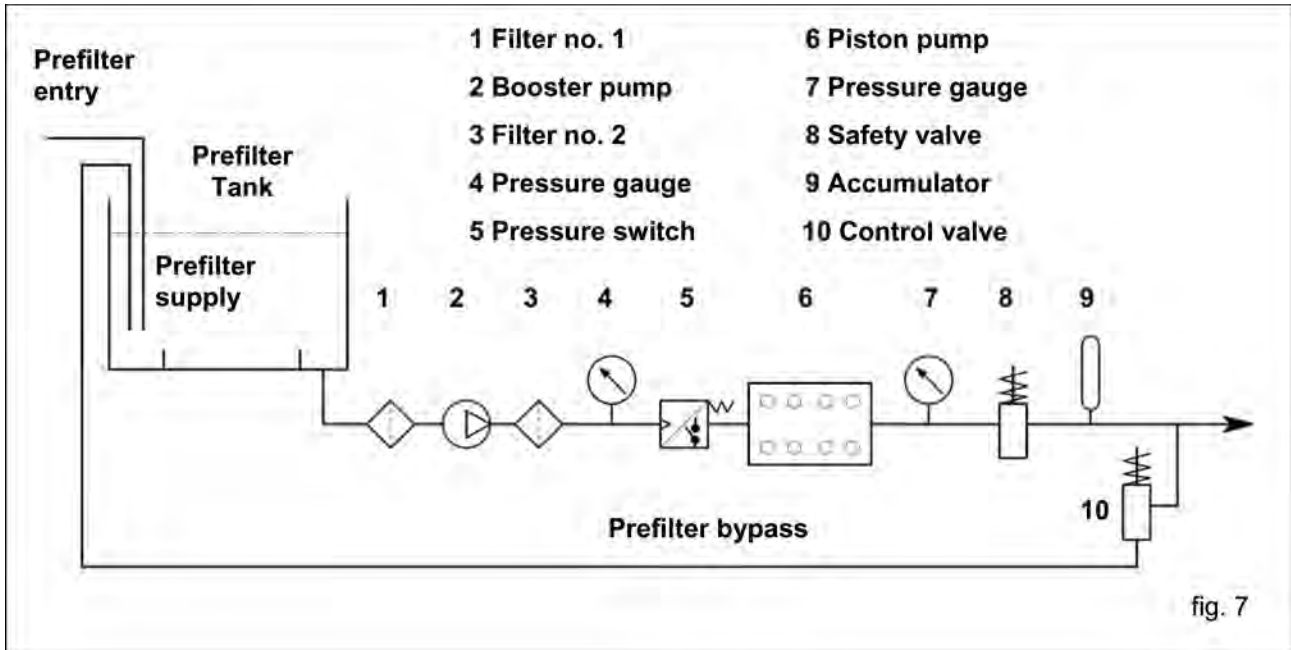

With pneumatically-actuated control valve:

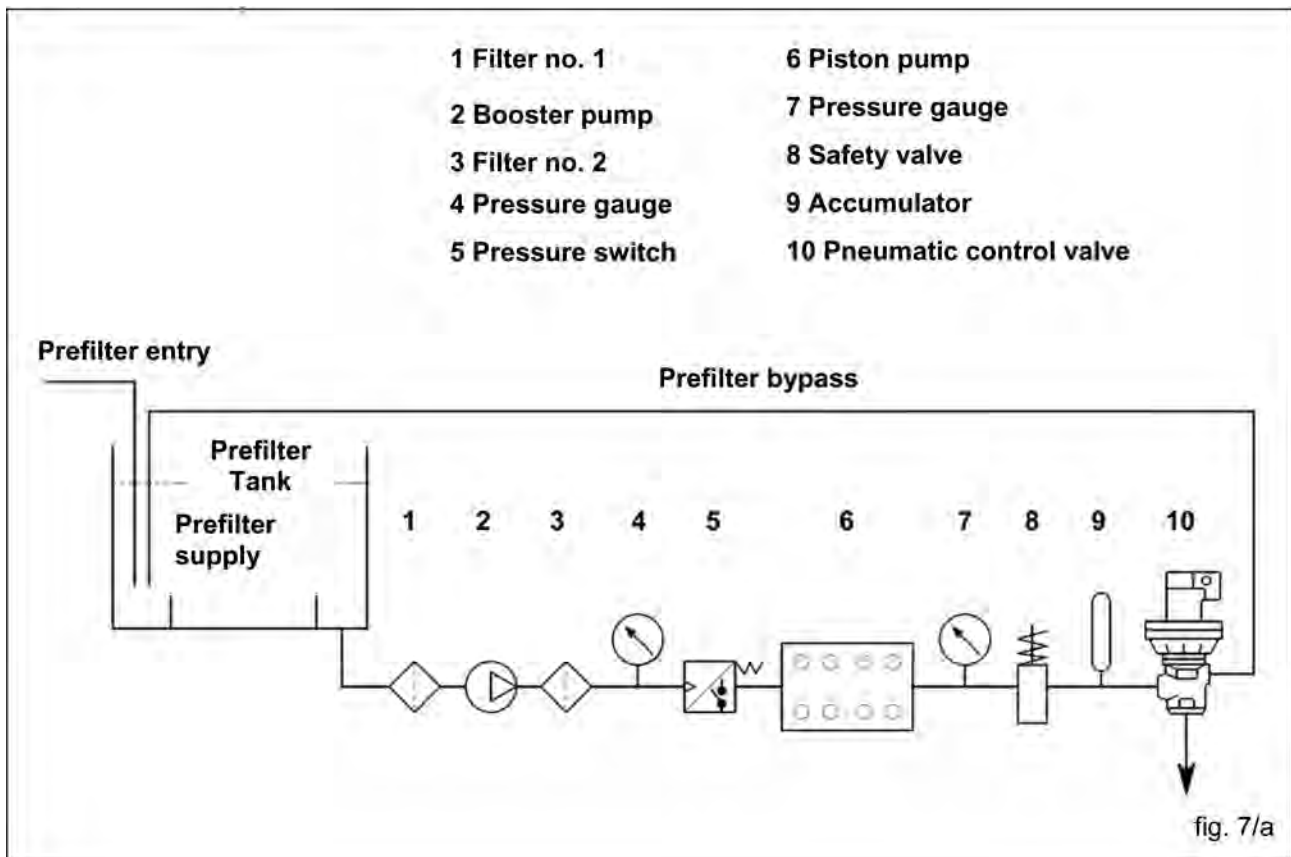

The filter must be installed as close as possible to the pump, should allow easy inspection and have the following characteristics:

1. Flow rate minimum 3 times greater than the pump's flow rate.
2. Diameter of the entry/exit apertures not less than the diameter of the pump's inlet port.
3. Filtration grade ranging between 200 and 360  $\mu\text{m}$ .



**For the pump to operate efficiently, the filter must be cleaned periodically. The cleaning frequency will need to be planned according to the actual use of the pump, and it should also take into account the quality of the water used and the effective congestion conditions.**

### 9.7 Outlet Line

For a correctly installed outlet or delivery line, follow these specifications:

1. The internal diameter of the hose must be sufficient to ensure the correct speed of the fluid; see diagram in paragraph 9.8.
2. The first section of hose connected to the pump must be flexible in order to isolate pump vibrations produced by the pump from the rest of the system.
3. Use high pressure hoses and fittings that guarantee wide safety margins in any working condition.
4. Install a safety valve on the outlet line.
5. Use pressure gauges suitable for the pulsating loads typical of plunger pumps.
6. In the design phase, take into proper account the pressure drop along the line, since this causes a reduction in usage pressure with respect to the value measured at the pump.
7. If the pump pulsations are harmful for particular applications, install an appropriately sized pulsation dampener on the outlet line.

### 9.8 Internal Diameter of the Hose Line

To determine the internal diameter of the hose, please refer to the following diagram:

#### Inlet Hose

With a flow rate of ~105 GPM (400 l/mn) and water speed of 1 m/sec. the diagram line that connects the two scales intersects the central scale, indicating the diameters, at a value of ~ 3.5 inch (90 mm).

#### Outlet Hose

With a flow rate of ~105 GPM (400 l/mn) and water speed of 5.5 m/sec. The diagram line that connects the two scales intersects the central scale, indicating the diameters at a value of ~ 1.6 inch (40 mm).

Optimum speed values:

- Inlet: ≤ 1 m/sec.
- Outlet: ≤ 5.5 m/sec.

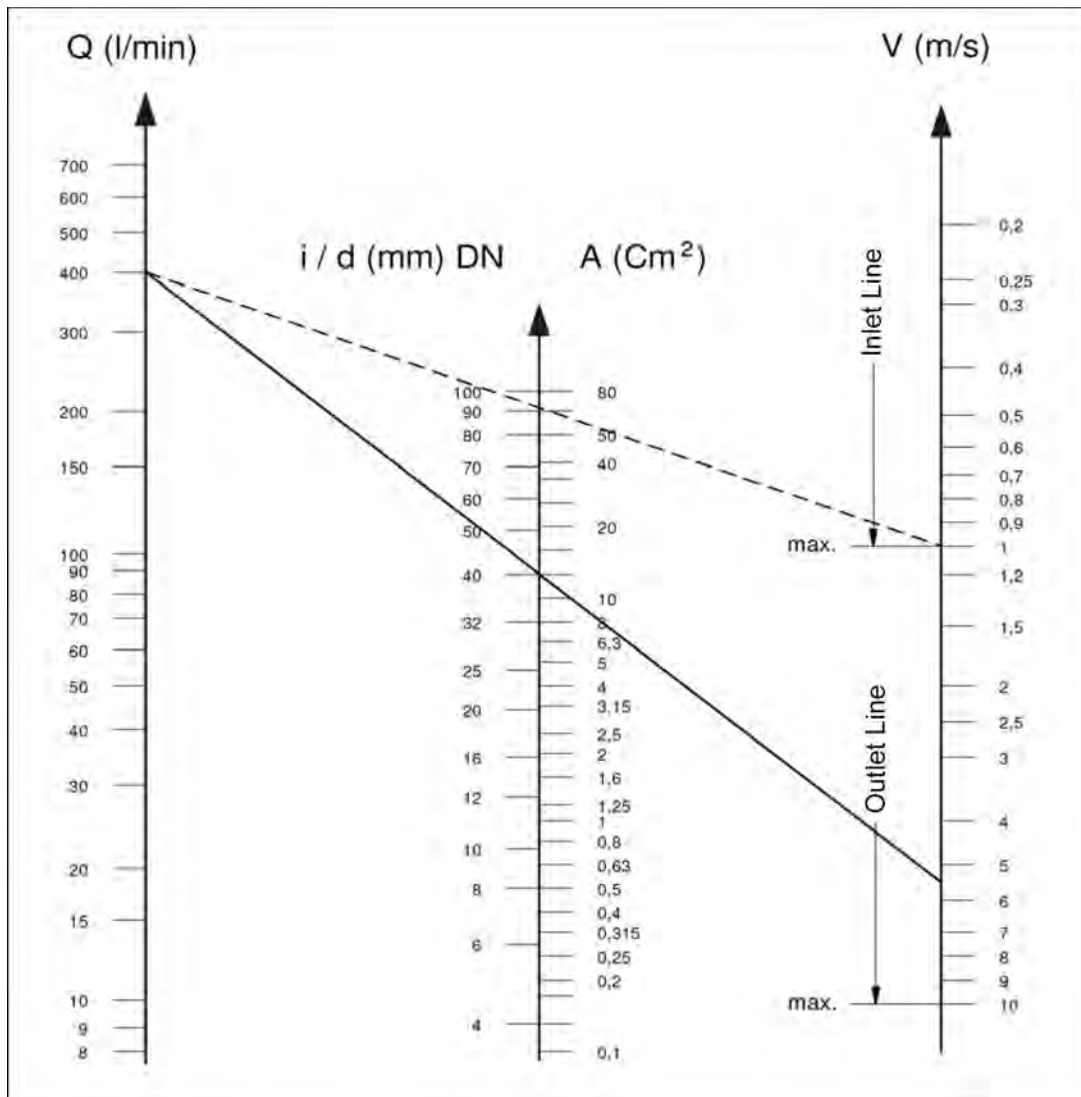

The diagram does not take into account the hose and valve resistance, the pressure drop due to the pipe length, the viscosity and the temperature of the pumped fluid. If necessary, contact our Customer Service Department.

## 10. START-UP AND OPERATION

### 10.1 Preliminary Inspections

Before Start-up Be sure that:



**The inlet line is connected and up to pressure (see Chapter 9) the pump must NEVER run dry.**

1. The suction line must be perfectly airtight.
2. All the On-Off valves between the pump and the feeding source are completely open. The outlet line must discharge freely in order to allow the air in the pump to be expelled easily, thus facilitating pump priming.
3. All inlet/outlet connections and fittings must be correctly tightened.
4. Coupling tolerances on the pump/transmission axis (half-joint misalignment, Cardan inclination, belt tightening, etc.) must remain within the limits indicated by the transmission Manufacturer.
5. The pump's oil level must be verified using the oil level lights (position 1, fig 8).

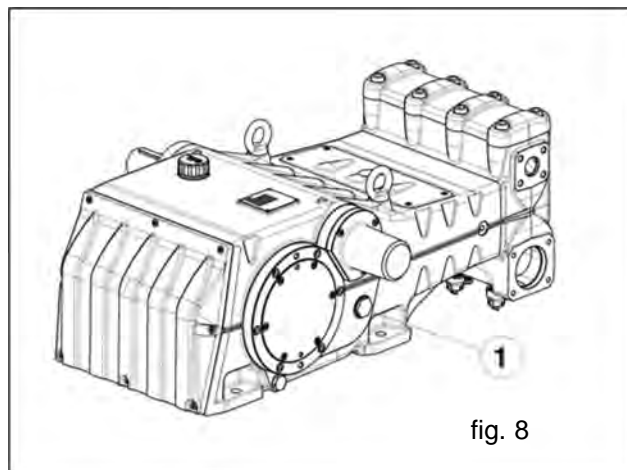

**If the pump has been in storage or inactive for a lengthy period, the inlet valves must be restored to their proper working condition by opening the three valve lifters (pos. 2, fig. 9). Make sure the valves are closed again before starting the pump. For the “working” and “stop” positions see fig. 10.**

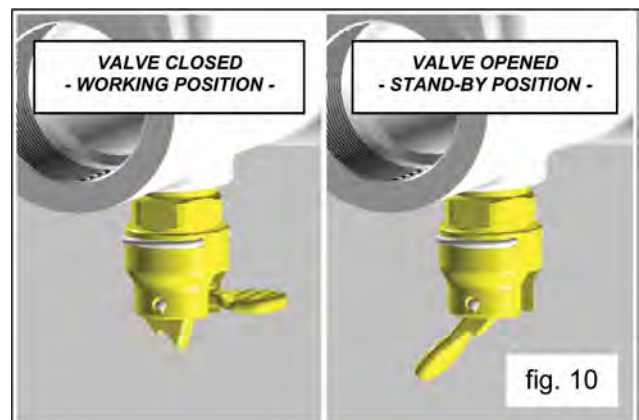
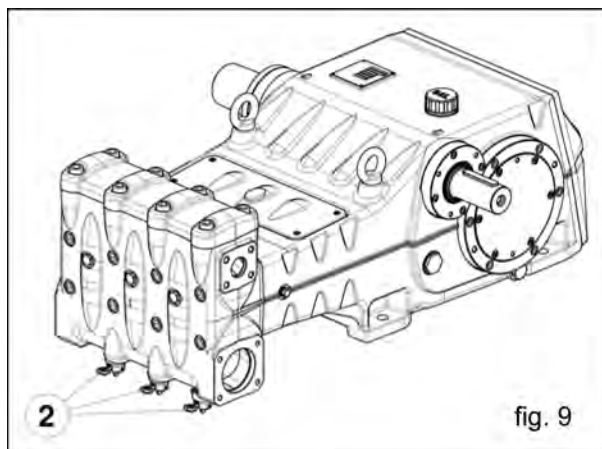



## 10.2 Start-up

1. When starting the pump for the first time, check for the correct direction of rotation.
2. Check the pump's water supply is correct.
3. The pump must be started off-load.
4. Verify that when operating, the rotation speed does not exceed the rated speed.
5. Allow the pump to operate for not less than 3 minutes before putting it under pressure.
6. Before stopping the pump, always bring the pressure down to zero first, using the control valve or (if present) relief devices.



**If there are problems with priming because of insufficient supply, this can be addressed by removing the three plugs on the front of the head (this does not apply to the LK36 version) as shown in pos. 3, fig. 11.**

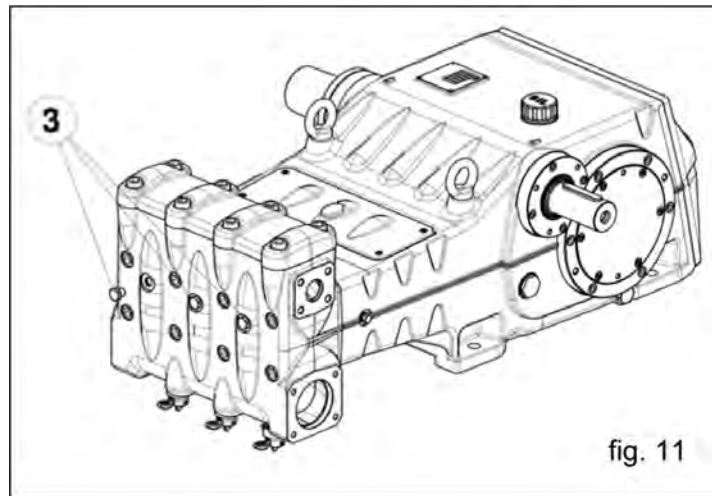

fig. 11

## 11. PREVENTIVE MAINTENANCE

To guarantee pump reliability and efficiency, the maintenance intervals shown in the table below must be observed.

PREVENTIVE MAINTENANCE	
EVERY 500 HOURS	EVERY 1500 HOURS
Check oil level	Change oil
	Check / Replace: <ul style="list-style-type: none"> <li>• Valves</li> <li>• Valve seats</li> <li>• Valve springs</li> <li>• Valve holders</li> </ul>
	Check / Replace: <ul style="list-style-type: none"> <li>• H.P packings</li> <li>• L.P. packings</li> </ul>



**ATTENTION: Replace all the bearings and the corresponding seals rings every 10000 hours of operation.**

Perform periodical checks on cleaning and maintenance on the pump. See the "ATEX EXPLOSION PROTECTION" manual.

## 12. STOPPING THE PUMP FOR LONG PERIODS

### 12.1 Filling the Pump With An Anti-Corrosion Emulsion or Anti-freeze By Using An External Diaphragm Pump As In The Layout Shown in Paragraph 9.6.

- a) Close the filter draining, if open.
- b) Be sure that the connecting hose is clean, spread with grease and connect it to the high pressure outlet port.
- c) Connect the inlet hose to the diaphragm pump. Open the inlet connection of the pump and connect the hose between this and the diaphragm pump.
- d) Fill the container with the solution/emulsion.
- e) Put the free ends of the high pressure inlet line and the outlet hose inside the container.
- f) Start up the diaphragm pump.
- g) Pump the emulsion until it comes out of the high pressure outlet hose.
- h) Continue pumping for at least another minute; if needed, the emulsion can be reinforced by adding, for example, Shell Donax
- i) Stop the pump, remove the hose from the inlet connection and close it with a plug.
- j) Remove the hose from the high pressure outlet port. Clean, grease and plug both connections and the hoses.

### 12.2 Hoses

- a) Before greasing and protecting the hoses according to the previously described procedure, dry the connections using compressed air.
- b) Cover with polyethylene.
- c) Do not wrap them too tightly; be sure there is no bending.

## 13. PRECAUTIONS AGAINST FREEZING



In areas and periods of the year where there is risk of freezing, follow the instructions indicated in Chapter 12 (see paragraph 12.1).



**In the presence of ice, in no case must the pump be started until the entire circuit has been completely thawed out; not complying with this indication may cause serious damage to the pump.**

## 14. WARRANTY TERMS

The warranty period and conditions are contained in the purchase contract. The warranty is void if:

- a) The pump has been used for purposes that differ from that agreed.
- b) The pump has been fit with an electric or diesel engine with performance greater than that indicated in the table.
- c) The required safety devices are unset or disconnected.
- d) The pump was used with accessories or spare parts not supplied by General Pump.
- e) Damage was caused by:
  - 1) improper use
  - 2) the non-observance of maintenance instructions
  - 3) use not compliant with operating instructions
  - 4) insufficient flow rate
  - 5) faulty installation
  - 6) incorrect positioning or sizing of the hoses
  - 7) non-authorized design changes
  - 8) cavitation

## 15. TROUBLESHOOTING



**The pump does not produce any noise at start-up:**

- The pump is not primed and is running dry
- There is no water in the inlet line
- The valves are blocked
- The delivery line is closed and does not allow the air in the pump to be discharged

**The pump pulses irregularly (knocking):**



- Air suction
- Insufficient feeding
- Bends, elbows, fittings along the inlet line obstruct the fluid's passage
- The inlet filter is dirty or too small
- The booster pump, where provided, supplies insufficient pressure or flow rate
- The pump is not primed due to insufficient head or the delivery line is closed during priming
- The pump is not primed due to valve seizing
- Worn valves
- Worn pressure packings
- Incorrect operation of the pressure adjustment valve
- Transmission problems



**The pump does not deliver the rated flow / is noisy:**

- Insufficient feeding (see the causes listed above)
- RPM are less than the rated flow
- Excessive amount of water by-passed by the pressure adjustment valve



- Worn valves
- Leakage from the pressure packings
- Cavitation due to:
  - 1) Wrong sizing of the suction hose/ undersized diameters
  - 2) Insufficient flow rate
  - 3) High water temperature



**Insufficient pump pressure:**

- The nozzle (or has become) too large
- Insufficient RPM
- Leakage from the pressure packings
- Incorrect operation of the pressure adjustment valve
- Worn valves



**Overheated pump:**

- The pump is overloaded (pressure or RPM exceed the rated values)
- Oil level is too low, or the oil is not of a suitable type, indicated in Chapter 7 (see paragraph 7.4)
- Incorrect alignment of the joint or pulleys
- Excessive inclination of the pump during operation



**Pump vibrations or knocking:**

- Air suction
- Incorrect operation of the pressure adjustment valve
- Valve malfunction
- Irregular drive transmission motion

**16. EXPLODED VIEW AND PARTS LIST**

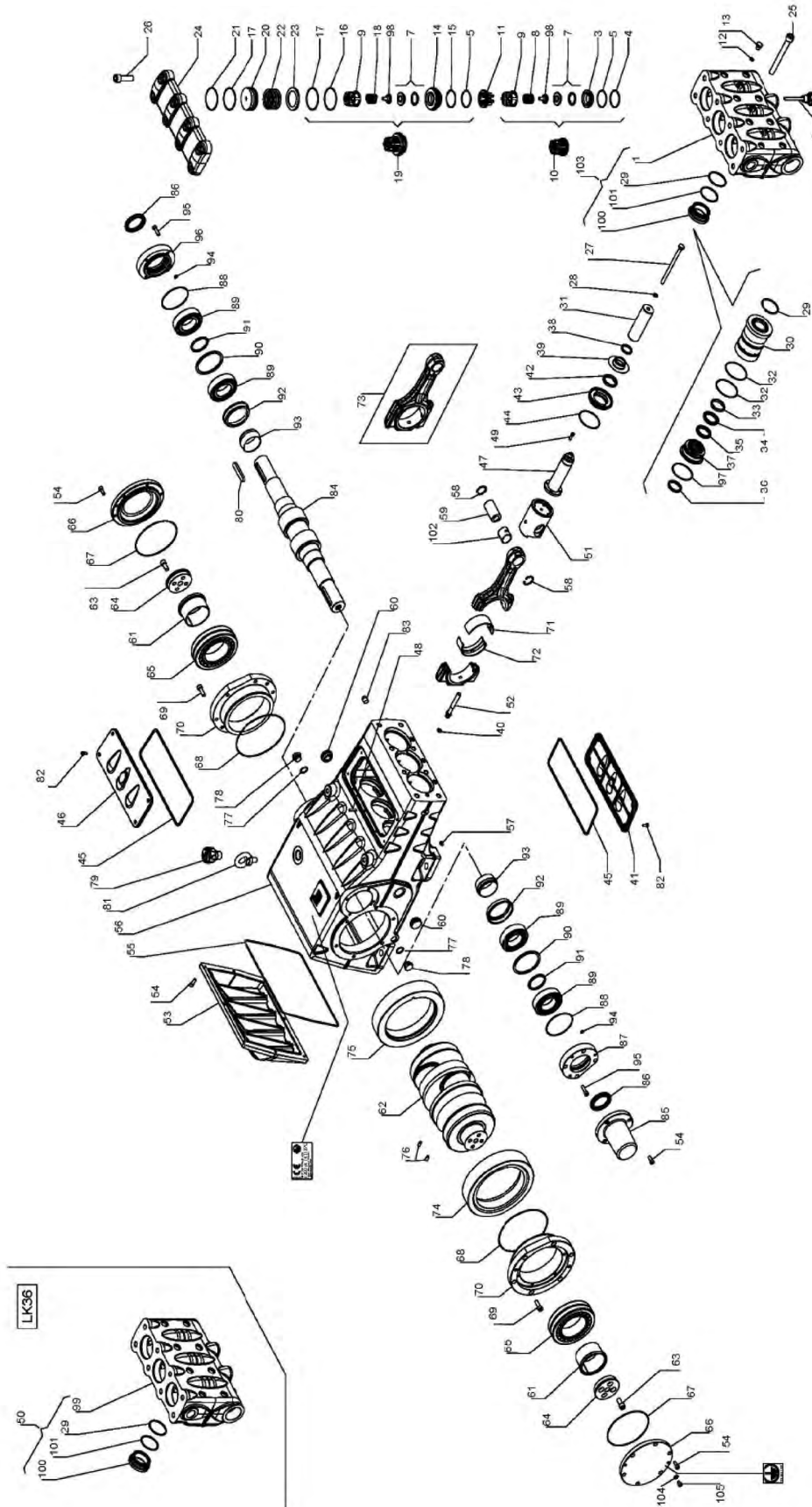

**LK HP**

Item	Part #	Description	QTY.
1	F78120415	Manifold, LK40, LK45	1
	F78120615	Manifold, LK40, LK45, NPT	1
2	F10744401	Drain Valve	3
	F10744501	Drain Valve, ATEX	3
3	F36206766	Seat, Valve, Inlet	3
4	F90526000	Anti-extrusion Ring, Ø 51.5x56x1.5	3
5	F90389000	O-ring, Ø 50.47x47x2.62	6
7	F36208801	Spherical Valve Assembly	6
8	F94760000	Spring, Ø 28.3x30.7	3
9	F36206105	Valve Cage	6
10	F36715101	Valve Assembly, Inlet	3
11	F74210651	Valve Part	3
12	90358400	O-ring, Ø 10.82x1.78	3
13	F98204600	Plug, G1/4"x13-INOX	3
14	F36206966	Seat, Valve, Outlet	3
15	F90526500	Anti-extrusion Ring, Ø 51.7x56.2x1.5	3
16	F90527600	Anti-extrusion Ring, Ø 67.5x72x1.5	3
17	F90391100	O-ring, Ø 66.35x2.62	6
18	F94760500	Spring, Ø 28.5x32	3
19	F36715301	Valve Assembly, Outlet	3
20	F74211070	Valve Plate	3
21	F90528000	Anti-extrusion Ring, Ø 67.7x72.2x1.5	3
22	F94775000	Spring, Ø 58x45.4	3
23	F74210866	Washer	3
24	F74210315	Valve Cover	1
25	F99521200	Screw, TCEI, M16x150	8
26	F99514700	Bolt, TCEI, M16x55	8
27	F99385000	Bolt, Plunger	3
28	F96710500	O-ring, Ø 10x18x0.9	3
29	F90410200	O-ring, Ø 58.74x3.53	3
30	F78216056	Plunger Guide, Ø 36 (LK36)	6
	F78216156	Plunger Guide, Ø 40 (LK40)	3
	F78216256	Plunger Guide, Ø 45 (LK45)	3
31	F78041209	Plunger, Ø 36x127 (LK36)	3
	F74040009	Plunger, Ø 40x127 (LK40)	3
32	F74040109	Plunger, Ø 45x127 (LK45)	3
	F90391450	O-ring, Ø 75.87x2.62	6
33	F78100192	Piston Ring, Ø 36 (LK36)	3
	F74100092	Piston Ring, Ø 40 (LK40)	3
	F74100192	Piston Ring, Ø 45 (LK45)	3
34	90282000	Packing Retainer, Ø 36x48x6, H.P. (LK36)	3
	90285000	Packing Retainer, Ø 40x55x7.5, H.P. (LK40)	3
	90283200	Packing Retainer, Ø 45x60x4.5, H.P. (LK45)	3
35	90281800	Restop Ring, Ø 36x48x6/3 (LK36)	3
	F90283800	Restop Ring, Ø 40x55/8/4.5 (LK40)	3
	90284800	Restop Ring, Ø 45x60x3/6.5 (LK45)	3
36	F90279800	Ring, Ø 36x44x5.5, L.P. (LK36)	3
	F90282800	Ring, Ø 40x48x5.5, L.P. (LK40)	3
	F90284600	Ring, Ø 45x53x5.5, L.P. (LK45)	3
37	F78216368	Packing Support Ø 36 (LK36)	3
	F78216468	Packing Support Ø 40 (LK40)	3
	F78216568	Packing Support Ø 45 (LK45)	3
38	F78214670	Wiper Ring	3
39	F78215302	Wiper	3
40	701111	O-ring, Ø 10.78x2.62	3
41	F74150222	Lower Cover	1
42	F90167900	Ring, Rad. 40x52x7	3
43	F78213771	Plunger Oil Seal Cover	3
44	F90391400	O-ring, Ø 72.69x2.62	3
45	F90450000	O-ring, Ø 266.06x5.34	2
46	F74150122	Upper Cover	1
47	F78050336	Sleeve	3
48	F99191600	Screw, M6x30	3
49	F99188400	Screw, M6x20	12
51	F78120301	Manifold Bushing Ø 36	1
50	F79050443	Piston Guide	3
	F79050543	Piston Guide, +1 Flange	3

Item	Part #	Description	QTY.
52	F99441000	Screw, M12x1.25x87	6
53	F78160020	Crankcase Cover	1
54	99305900	Screw, M8x20	23
55	F90417000	O-ring, Ø 355.19x3.53	1
56	F78010013	Crankcase	1
57	F98195500	Plug, Ø 9x10	1
58	F90069700	Ring, Snap	6
59	F97745000	Wrist Pin, Ø 35x64	3
60	F97597800	Oil Level Indicator, G1"	2
61	F78214200	Bearing Bushing	2
62	F78020035	Crankshaft Sleeve	1
63	F99426800	Screw, M12x25	8
64	F78213955	Bearing Bushing Retainer Flange	2
65	F91886200	Roller Bearing	2
66	F78150220	Bearing Cover	2
67	F90392900	O-ring, Ø 152.07x2.62	2
68	F90394000	O-ring, Ø 183.62x2.62	2
69	99368600	Bolt, M10x30	12
70	F78150013	Bearing Cover	2
71	F90930000	Semi-circ. Connecting Rod, Inf.	3
	F90930100	Semi-circ. Connecting Rod, +0.25, Inf.	3
	F90930200	Semi-circ. Connecting Rod, +0.50, Inf.	3
72	F90931000	Semi-circ. Connecting Rod, Sup.	3
	F90931100	Semi-circ. Connecting Rod, +0.25 Sup.	3
	F90931200	Semi-circ. Connecting Rod, +0.50 Sup.	3
73	F78030101	Connecting Rod Assembly	3
74	F10072735	Bearing, External, Z59, R2,95	1
	F70073135	Bearing, External, Z61, R3,389	1
	F10072935	Bearing, External, Z60, R3,158	1
75	F10072835	Bearing, Internal, Z59, R2,95	1
	F10073235	Bearing, Internal, Z61, R3,389	1
	F10073035	Bearing, Internal, Z60, R3,158	1
76	F97618500	Pin, Locator, Ø 8x18	2
77	96751400	Gasket, Ø 21.5x27x1.5	2
78	F98218700	Plug, G1/2"x10	2
	F98218700	Plug, G1/2"x10 - ATEX	1
79	F98208150	Plug, G1/2"x13 SS - ATEX	1
	F98233300	Plug, Oil, G1"	1
80	F91501000	Key	1
81	F93105000	Lift Ring, M16	2
82	99183700	Screw, M6x14 Gr. 8.8	8
83	F98208700	Plug, 3/8"	1
84	F10073355	Pinion, Z20, R2,95	1
	F10073555	Pinion, Z18, R3,389	1
	F10073455	Pinion, Z19, R3,158	1
85	F78150120	Cover, Crankshaft End	1
86	F90172400	Ring, Rad., Ø 55x75x8	2
87	F78150320	Bearing Cover	1
88	90391800	O-ring, Ø 94.92x2.62	2
89	F91859700	Needle Bearing	4
90	F78214089	Spacer, External	2
91	F78214189	Spacer, Internal	2
92	F78214489	Lubricating Bushing	2
93	F78214389	Conical Lubrication Cover	2
94	90358100	O-ring, Ø 8.73x1.78	2
95	99308400	Screw, Hex, M8x30	8
96	F78150420	Bearing Cover	1
97	F90391350	O-ring, Ø 71.12x2.62	3
98	F36209051	Internal Valve Guide	6
99	F78120315	Manifold LK36	1
	F78120515	Manifold LK36 - NPT	1
100	F78216756	Head Bushing	3
101	F90526880	Anti-extrusion Ring Ø59x65x1.5	3
102	F90917300	Connecting Rod Bushing	3
103	F78120401	Manifold Bushing Ø 40, Ø 45	1
104	F96701750	Washer Ø 8.4x15x0.8 - ATEX	1
105	F99301900	Screw M8x10 - ATEX	1

**REPAIR KITS**

KIT NUMBER	F2113 (LK36) Plunger Packing Kit	F2114 (LK40) Plunger Packing Kit	F2115 (LK45) Plunger Packing Kit	F2055 Valve Kit	F2116 (LK36) Complete Seals Kit	F2117 (LK40) Complete Seals Kit	F2118 (LK45) Complete Seals Kit	F2076 Connecting Rod Bushing Kit	F2077 +0.25 Connecting Rod Bushing Kit	F2078 +0.50 Connecting Rod Bushing Kit
Positions Included	29, 32, 34, 35, 36, 97	29, 32, 34, 35, 36, 97	29, 32, 34, 35, 36, 97	10, 17, 19, 21	4, 5, 12, 15, 16, 17, 21, 29, 32, 34, 35, 36, 40, 42, 44, 45, 55, 67, 68, 86, 88, 89, 97	4, 5, 12, 15, 16, 17, 21, 29, 32, 34, 35, 36, 40, 42, 44, 45, 55, 67, 68, 86, 88, 89, 97	4, 5, 12, 15, 16, 17, 21, 29, 32, 34, 35, 36, 40, 42, 44, 45, 55, 67, 68, 86, 88, 89, 97	71, 72	71, 72	71, 72

**16. EXPLODED VIEW AND PARTS LIST**

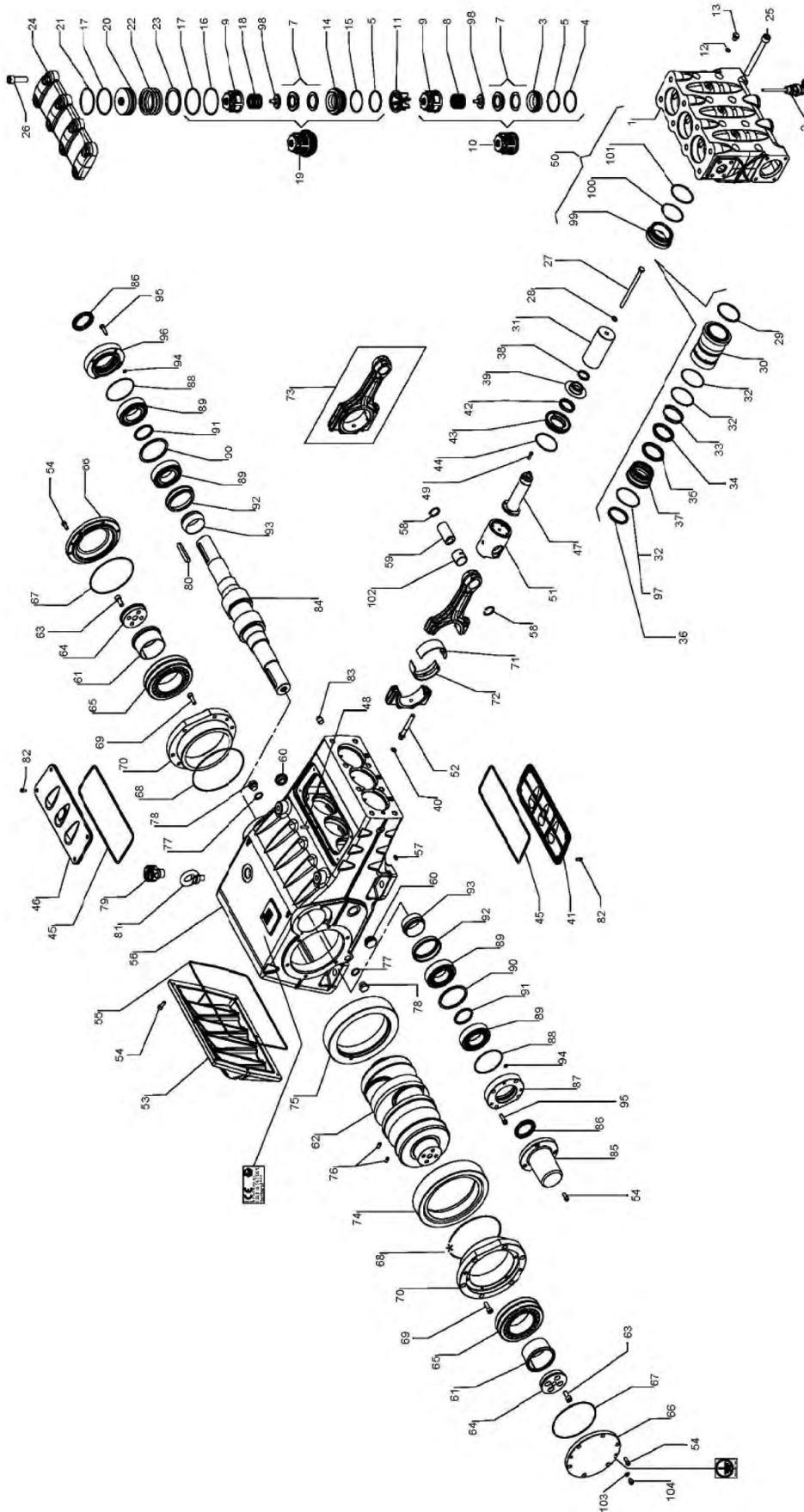

Item	Part #	Description	QTY.
1	F78120115	Manifold	1
2	F10744301	Drain Valve	3
	F10745001	Drain Valve - ATEX	3
3	F36206666	Seat, Valve, Inlet	3
4	F90527000	Anti-extrusion Ring, Ø51.5x56x1.5	3
5	F90410500	O-ring, Ø 59.92x3.53	6
7	F36208701	Spherical Valve Assembly	6
8	F94769800	Spring, Ø 41.5x37.9	3
9	F36206005	Valve Cage	6
10	F36715001	Valve Assembly, Inlet	3
11	F74210551	Valve Part	3
12	90358400	O-ring, Ø 10.82x1.78	3
13	F98204600	Plug, G1/4"x13-INOX	3
14	F36206866	Seat, Valve, Outlet	3
15	F90527300	Anti-extrusion Ring, Ø 61.4x67.2x1.5	3
16	F90529000	Anti-extrusion Ring, Ø 77.2x83x1.5	3
17	F90413400	O-ring, Ø 75.8x3.53	6
18	F94770000	Spring, Ø 41.5x41.1	3
19	F36715201	Valve Assembly, Outlet	3
20	F74210970	Valve Plate	3
21	F90529300	Anti-extrusion Ring, Ø 77.4x83.2x1.5	3
22	F94800000	Spring, Ø 75x49.6	3
23	F74210766	Washer	3
24	F74210115	Valve Cover	1
25	F99521200	Screw, TCEI, M16x150	8
26	F99514700	Bolt, TCEI, M16x55	8
27	F99385000	Bolt, Plunger	3
28	F96710500	O-ring, Ø 10x18x0.9	3
29	F90418500	O-ring, Ø 72x4	3
30	F78214756	Plunger Guide, Ø 50 (LK50)	3
	F78214856	Plunger Guide, Ø 55 (LK55)	3
	F78214956	Plunger Guide, Ø 60 (LK60)	3
31	F74040209	Plunger, Ø 50x127 (LK50)	3
	F74040309	Plunger, Ø 55x127 (LK55)	3
	F74040409	Plunger, Ø 60x127 (LK60)	3
32	F90391450	O-ring, Ø 75.87x2.62	6
33	F74100292	Piston Ring, Ø 50 (LK50)	3
	F74100392	Piston Ring, Ø 55 (LK55)	3
	F74100492	Piston Ring, Ø 60 (LK60)	3
34	F90286300	Packing Retainer, Ø 50x65x7.5/4.5, H.P. (LK50)	3
	F90287300	Packing Retainer, Ø 55x70x7.5/4.5 H.P. (LK55)	3
	F90288300	Packing Retainer, Ø 60x76x8/4.8, H.P. (LK60)	3
35	F90286500	Restop Ring, Ø 50x65x8/4.5 (LK50)	3
	F90287500	Restop Ring, Ø 55x70x8/4.5 (LK55)	3
	F90288500	Restop Ring, Ø 60x76x8/4.5 (LK60)	3
36	F90286000	Ring, Ø 50x58x5.5, L.P. (LK50)	3
	F90287000	Ring, Ø 55x63x5.5, L.P. (LK55)	3
	F90288000	Ring, Ø 60x68x5.5, L.P. (LK60)	3
37	F78215068	Packing Support Ø 50 (LK50)	3
	F78215168	Packing Support Ø 55 (LK55)	3
	F78215268	Packing Support Ø 60 (LK60)	3
38	F78214670	Wiper Ring	3
39	F78215302	Wiper	3
40	701111	O-ring, Ø 10.78x2.62	3
41	F74150222	Lower Cover	1
42	F90167900	Ring, Rad. 40x52x7	3
43	F78213771	Plunger Oil Seal Cover	3
44	F90391400	O-ring, Ø 72.69x2.62	3
45	F90450000	O-ring, Ø 266.06x5.34	2
46	F74150122	Upper Cover	1
47	F78050336	Sleeve	3
48	F99191600	Screw, M6x30	3
49	F99188400	Spine, Ø 5x16	3
50	F78120101	Bolt, M10x35	3
51	F79050443	Piston Guide	3
	F79050543	Piston Guide, +1.0	3

Item	Part #	Description	QTY.
52	F99441000	Screw, M12x1.25x87	6
53	F78160020	Crankcase Cover	1
54	99305900	Screw, M8x20	23
55	F90417000	O-ring, Ø 355.19x3.53	1
56	F78010013	Crankcase	1
57	F98195500	Plug, Ø 9x10	1
58	F90069700	Ring, Snap	6
59	F97745000	Wrist Pin, Ø 35x64	3
60	F97597800	Oil Level Indicator, G1"	2
61	F78214200	Bearing Bushing	2
62	F78020035	Crankshaft Sleeve	1
63	F99426800	Screw, M12x25	8
64	F78213955	Bearing Bushing Retainer Flange	2
65	F91886200	Roller Bearing	2
66	F78150220	Bearing Cover	2
67	F90392900	O-ring, Ø 152.07x2.62	2
68	F90394000	O-ring, Ø 183.62x2.62	2
69	99368600	Bolt, M10x30	12
70	F78150013	Bearing Cover	2
71	F90930000	Semi-circ. Connecting Rod, Inf.	3
	F90930100	Semi-circ. Connecting Rod, +0.25, Inf.	3
	F90930200	Semi-circ. Connecting Rod, +0.50, Inf.	3
72	F90931000	Semi-circ. Connecting Rod, Sup.	3
	F90931100	Semi-circ. Connecting Rod, +0.25 Sup.	3
	F90931200	Semi-circ. Connecting Rod, +0.50 Sup.	3
73	F78030101	Connecting Rod Assembly	3
74	F10072735	Bearing, External, Z59, R2,95	1
	F70073135	Bearing, External, Z61, R3,389	1
	F10072935	Bearing, External, Z60, R3,158	1
75	F10072835	Bearing, Internal, Z59, R2,95	1
	F10073235	Bearing, Internal, Z61, R3,389	1
	F10073035	Bearing, Internal, Z60, R3,158	1
76	F97618500	Pin, Locator, Ø 8x18	2
77	96751400	Gasket, Ø 21.5x27x1.5	2
78	F98218700	Plug, G1/2"x10	2
	F98218700	Plug, G1/2"x10 - ATEX	1
	F98208150	Plug, G1/2"x10 SS - ATEX	1
79	F98232800	Plug, Oil, G1"	1
	F98233400	Plug, Oil, G1" - ATEX	1
80	F91501000	Key	1
81	F93105000	Lift Ring, M16	2
82	99183700	Screw, M6x14 Gr. 8.8	8
83	F98208700	Plug, 3/8"	1
84	F10073355	Pinion, Z20, R2,95	1
	F10073555	Pinion, Z18, R3,389	1
	F10073455	Pinion, Z19, R3,158	1
85	F78150120	Cover, Crankshaft End	1
86	F90172400	Ring, Rad., Ø 55x75x8	2
87	F78150320	Bearing Cover	1
88	90391800	O-ring, Ø 94.92x2.62	2
89	F91859700	Needle Bearing	4
90	F78214089	Spacer, External	2
91	F78214189	Spacer, Internal	2
92	F78214489	Lubricating Bushing	2
93	F78214389	Conical Lubrication Cover	2
94	90358100	O-ring, Ø 8.73x1.78	2
95	99308400	Screw, Hex, M8x30	8
96	F78150420	Bearing Cover	1
97	F90391350	O-ring, Ø 71.12x2.62 LK50	3
98	F36208951	Internal Valve Guide	6
99	F78216656	Head Bushing	3
100	F90528500	Anti-extrusion Ring Ø 72.5x78.5x1.5	3
101	F90412900	O-ring, Ø 72.62x3.53	3
102	F90917300	Connecting Rod Bushing	3
103	F96701750	Washer, Ø 8.4x15x0.8 - ATEX	1
104	F99301900	Screw M8x10 - ATEX	1

**REPAIR KITS**

KIT NUMBER	F2093 (LK50) Plunger Packing Kit	F2094 (LK55) Plunger Packing Kit	F2095 (LK60) Plunger Packing Kit	F2048 Valve Kit	F2097 (LK50) Complete Seals Kit	F2098 (LK55) Complete Seals Kit	F2099 (LK60) Complete Seals Kit	F2076 Connecting Rod Bushing Kit	F2077 +0.25 Connecting Rod Bushing Kit	F2078 +0.50 Connecting Rod Bushing Kit
Positions Included	29, 32, 34, 35, 36, 97	29, 32, 34, 35, 36, 97	29, 32, 34, 35, 36, 97	10, 11, 17, 19, 21	4, 5, 12, 15, 16, 17, 21, 29, 32, 34, 35, 36, 40, 42, 44, 45, 55, 67, 68, 86, 88, 94, 97	4, 5, 12, 15, 16, 17, 21, 29, 32, 34, 35, 36, 40, 42, 44, 45, 55, 67, 68, 86, 88, 94, 97	4, 5, 12, 15, 16, 17, 21, 29, 32, 34, 35, 36, 40, 42, 44, 45, 55, 67, 68, 86, 88, 94, 97	71, 72	71, 72	71, 72

## MAINTENANCE LOG

### HOURS & DATE

<b>OIL CHANGE</b>							
<b>GREASE</b>							
<b>PACKING REPLACEMENT</b>							
<b>PLUNGER REPLACEMENT</b>							
<b>VALVE REPLACEMENT</b>							



GP Companies, Inc.  
1174 Northland Drive  
Mendota Heights, MN 55120  
Phone: 651.686.2199 Fax: 800.535.1745  
www.generalpump.com email: sales@gpcompanies.com

Ref 300771 Rev.D  
03-20